

Please read instructions carefully. Remove all wrapping material, staples and packing straps from the carton. See Hardware and Furniture Parts List for guidance. Be sure you have all parts before you start assembling. Place all wooden furniture parts on a clean flat soft surface, such as carpet or rug to prevent from being scratched.

CAUTION:

(1) DO NOT FULLY-TIGHTEN THE NUTS OR SCREW INITIALLY UNTIL ALL THE NUTS OR SCREWS ARE ALREADY ASSEMBLED. (TO AVOID CAUSING DAMAGES TO THE THREAD, DO NOT OVER TIGHTEN THE NUTS OR SCREW).

(2) KEEP ALL HARDWARE PARTS OUT OF REACH OF CHILDREN

PARTS LIST

NO	DESCRIPTIONS	QTY
1	TABLE TOP	1
2	LEAF PANEL	1
3	BRACKET PANEL	1
4	DOORS PANEL	4
5	SIDE PANEL (R/L)	2
6	UNDER SHELF	1
7	MIDDLE SHELF	1
8	SHELF PANEL	1
9	STRETCHER (R/L)	2
10	DISK RACK	2

HARDWARE LIST

A.	B.	C.	D.	E.	F.	G.	H.	I.	K.	L.
HEX. NUT	BIG FLAT WASHER	BIG SPRING WASHER	SMALL FLAT WASHER	SMALL SPRING WASHER	LONG BOLT	SHORT BOLT	ALLEN KEY	SPANNER	KNOB	DOWEL
4 PCS	4 PCS	4 PCS	20 PCS	20 PCS	20 PCS	4 PCS	1 PC	1 PC	4 PCS	4 PCS

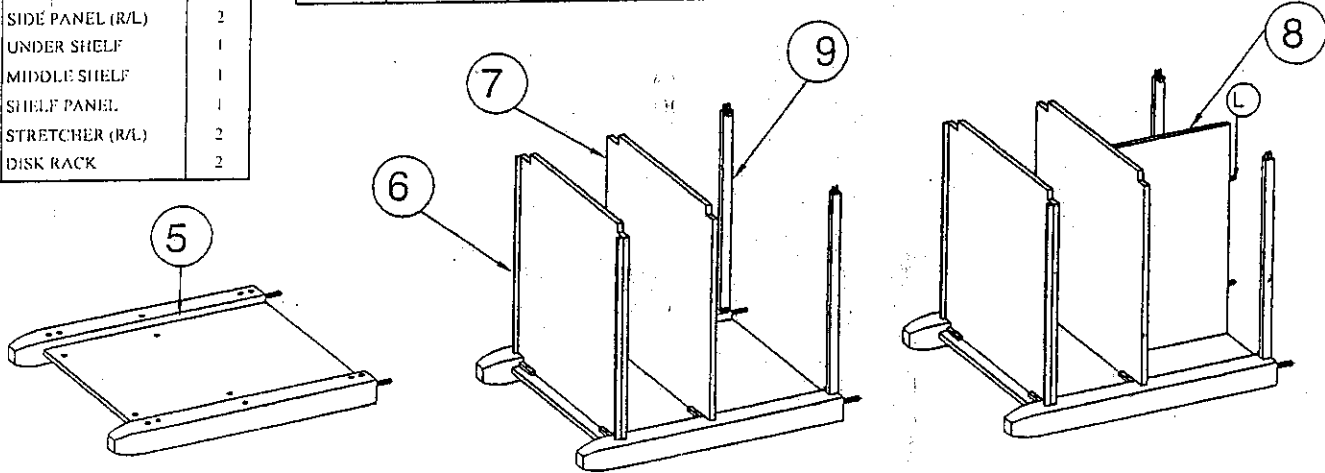

STEP1:

Place the right side panel(5) on the floor with a piece of cloth or carpet underneath to prevent the finish from scratching.

STEP2:

Attach the under shelf(6), middle shelf(7) and stretcher(9) to side panel(5). Tighten all the bolts with allen key(H).

STEP3:

Insert dowel(L) to shelf panel(8) and attach shelf panel(8) to middle panel(7)

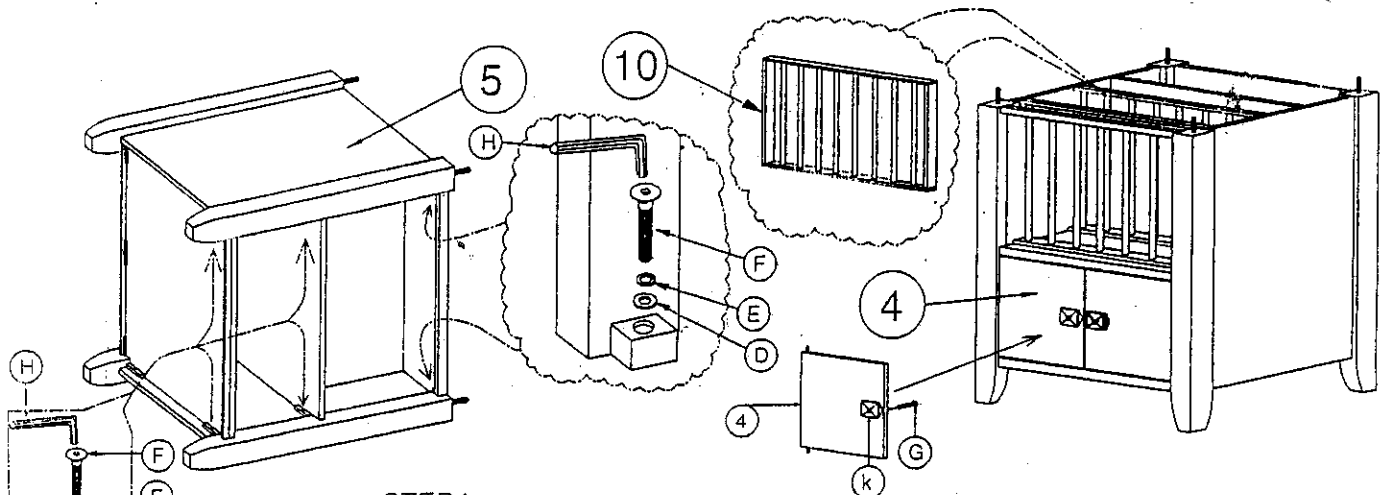

STEP4:

Place the left side panel(5) on them, Tighten all the bolts with allen key. Position all part right-upside as shown. Then, insert the disk rack(10) into the right its position, tighten all the bolts with allen key. Then, insert door panels(4) with knob(K) into the front and behind of set (notice its right position). Should be checked all bolts full tighten at this step.

STEP5:

Remove the bracket panel(3) from table top and take out the extension leaf carton box (2).

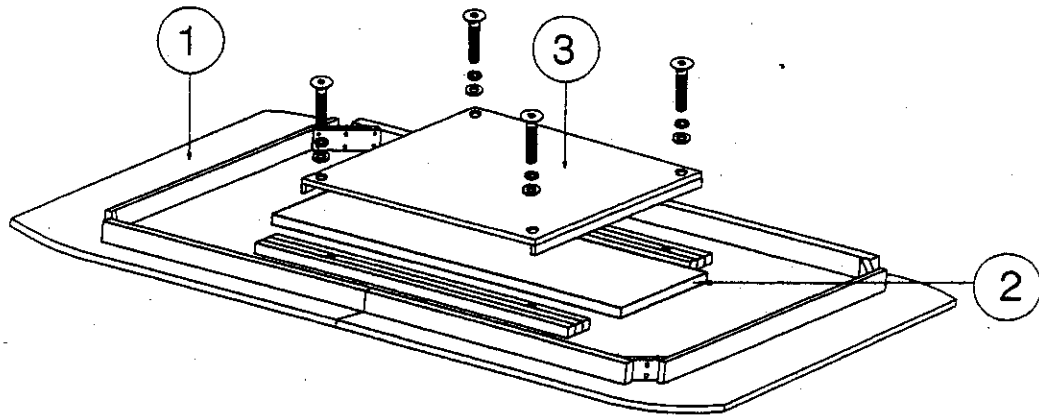

STEP6:

Take the bracket panel(3) from table top attach on this part. Use big flat washers(B),big spring washers(C) and hex nut(A) secure. Then, place the table top(1) on, Tighten all the bolts with allen key. Your product is now as shown.

