

LIST OF PARTS

NO.	QTY	DESCRIPTION
A	1 PC.	BACK FRAME
B	1 PC.	SEAT FRAME
C	2 PCS.	LEG FRONTS
D	1 PC.	FRONT STRETCHER
E	2 PCS.	SIDE STRETCHERS
F	2 PCS.	K.D. BOLTS (SHORT)
G	4 PCS.	K.D. BOLTS (LONG)
H	4 PCS.	NUTS
I	10 PCS.	LOCK WASHERS
J	10 PCS.	FLAT WASHERS
K	6 PCS.	WOOD SCREWS
L	1 PC.	KEY WRENCH

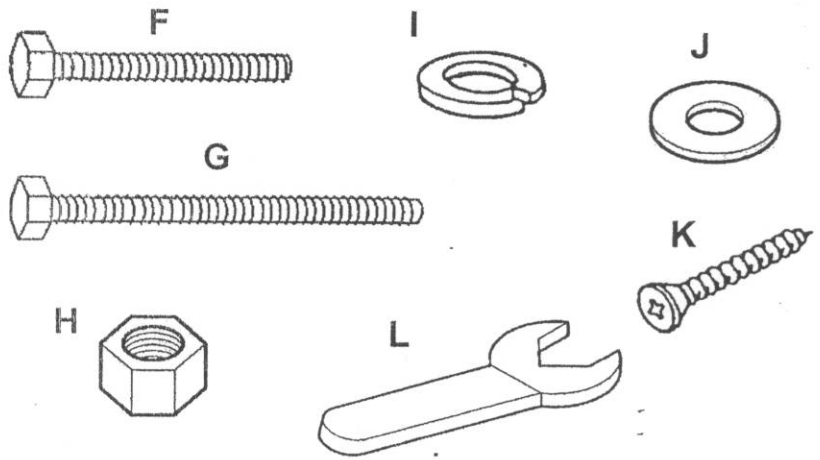

STEP : 1

- REMOVE ALL STOOL PARTS FROM THE CARTON.
- CUT THE CARTON CORNERS AND OPEN THE CARTON, SO THAT IT CAN BE USED AS A WORK SURFACE FOR ASSEMBLY.
- PLACE THE SEAT FRAME (B) ON THE BACK FRAME (A) AND INSERT A FLAT WASHER (J), LOCK WASHER (I) AND A SHORT K.D. BOLT (F) INTO EACH OF THE 2 HOLES ON THE BACK OF THE SEAT (SEE DETAIL : A) TIGHTEN THE SCREW WITH THE KEY WRENCH (L) BY TURNING CLOCKWISE UNTIL SECURE. (SEE DETAIL : A)
- INSERT THE FLAT WASHER (H), LOCK WASHER (I) AND LONG K.D. SCREW (G) INTO EACH OF THE 2 HOLES IN THE SEAT CORNERS, TIGHTEN THE SCREWS WITH THE KEY WRENCH (L) BY TURNING CLOCKWISE UNTIL SECURE. (SEE DETAIL : A)

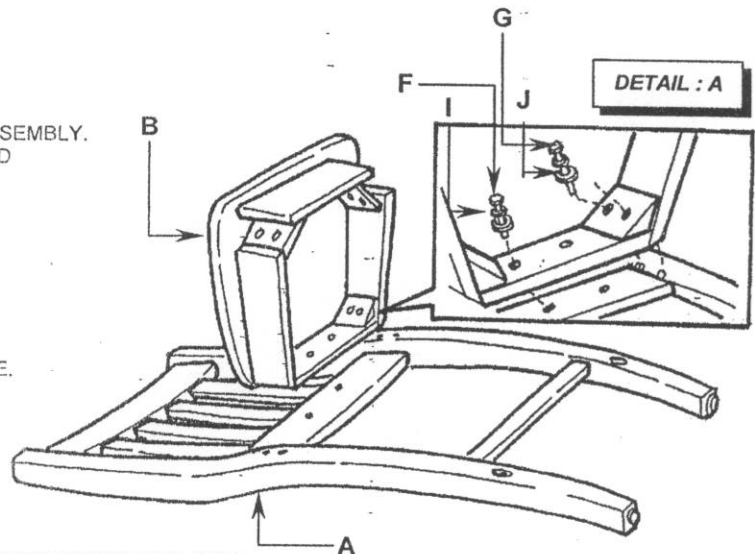

STEP : 2

- TURN THE STOOL OVER ON TABLE TOP OR COUNTER.
- ATTACH RIGHT AND LEFT FRONT LEG (C) TO THE FRONT OF THE SEAT FRAME (B).
- PLACE FLAT WASHER (J), LOCK WASHER (I) AND NUT (H) ON EACH BOLT.
- TURN THE NUT ON EACH BOLT SEVERAL TURNS WITH KEY WRENCH (L) BUT DO NOT TIGHTEN. (SEE DETAIL : B)
- INSERT 2 SIDE STRETCHERS (E) AND FRONT STRETCHER (D) INTO THE HOLES BETWEEN FRONT AND BACK LEG AND FASTEN WITH WOOD SCREWS (K) ON EACH USING PHILIPS HEAD SCREWDRIVER (NOT PROVIDED).
- TIGHTEN ALL BOLTS BEFORE USING CHAIR.

